



FA 波纹管紧密机械密封 (用于家用电器)

Compact elastomer bellows seal



特性 Characteristics

单端面密封 - Single seal

不平衡型 - Unbalanced

转向不限 - Direction of rotation independent

工作压力:真空/6 bar - Pressure to Vacuum / 6 bar

温度范围:-30/+200° C - Temperature -30/+200°C

最大线速度:12m/s max - Speed 12m/s max

尺寸L(工作长度)是指安装到工作位置时的长度(弹簧压下时)

The dimension L (working length) is in keeping with the working position (spring down)

组件名称	Description	材质	Materials
1	挡圈 Washer	不锈钢	Stainless steel
2	弹簧 Spring	不锈钢	Stainless steel
3	卡环 Collar ring	不锈钢	Stainless steel
4	垫圈 Gasket	橡胶	Rubber
5	壳体 Box	不锈钢	Stainless steel
6	动环 Slip ring	可选不同材质	Various
7	静环 Counterface	可选不同材质	Various
8	垫圈 Gasket	橡胶	Rubber

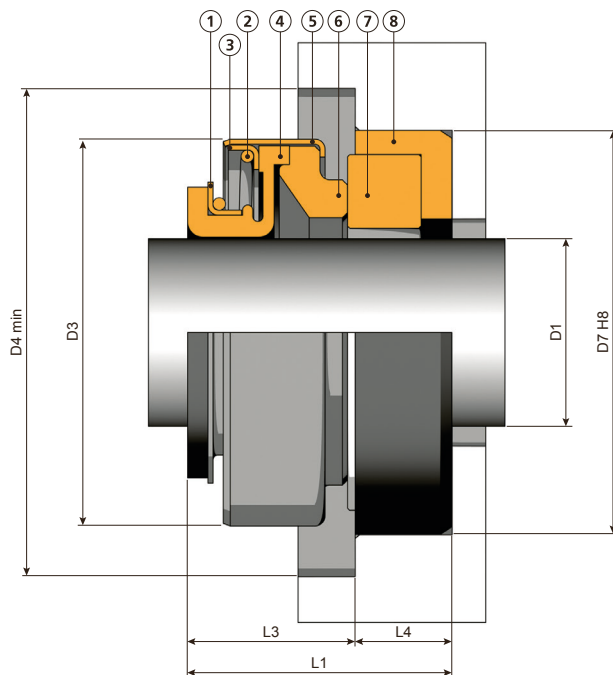

主动驱动型 FA positive driving - Type1

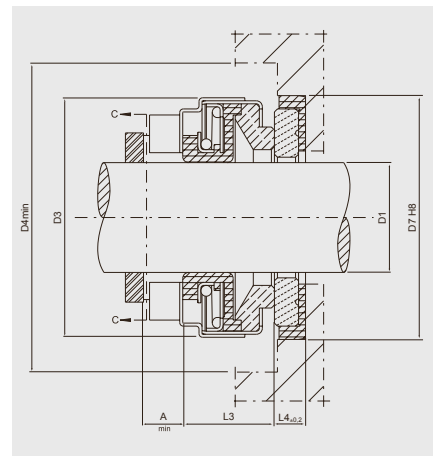

主动驱动型 FA positive driving - Type2

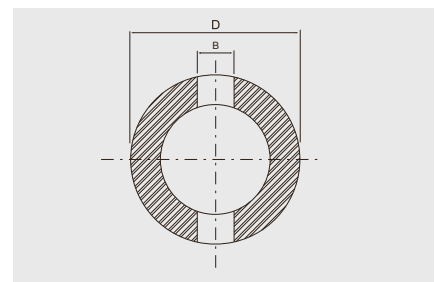
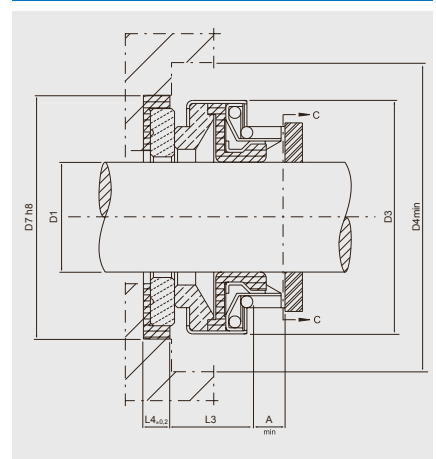



FA 波纹管紧密机械密封 (用于家用电器)

Compact elastomer bellows seal

FA

选型参数 Designation			D1	D3	L3	D4	D7	L4	L1
6	18	8,5	6±0,1	18	8,5±0,5	24	22	4	12,5
8	18	8,5	8±0,1	18	8,5±0,5	24	22	4	12,5
8	18	11	8±0,1	18	11±0,5	24	22	4	15
8	24	11	8±0,1	24	11	28	26	5,5/8	16,5/19
9	24	11	9±0,1	24	11	28	26	5,5/8	16,5/19
10	24	11	10±0,1	24	11	28	26	5,5/8	16,5/19
11	24	11	11±0,1	24	11	28	26	5,5/8	16,5/19
12	24	13	12±0,1	24	13	28	26	5,5/8	18,5/21
13	24	13	13±0,1	24	13	28	26	5,5/8	18,5/21
12	32	13	12±0,1	32	13	36/40	29,5/38	8	21
14	28	12,8	14±0,1	28	12,8	36	29,5/38	7,5	20,5
14	32	13	14±0,1	32	13	36/40	29,5/38	8	21
15	32	13	15±0,1	32	13	36/40	29,5/38	8	21
16	32	13	16±0,1	32	13	36/40	29,5/38	8	21
14	35	13	14±0,1	35	13	40	29,5/38	8	21
15	35	13	15±0,1	35	13	40	29,5/38	8	21
16	35	13	16±0,1	35	13	40	29,5/38	8	21
16	39	13	16±0,1	39	13	45	42	8	21
17	39	13	17±0,1	39	13	45	42	8	21
18	39	13	18±0,1	39	13	45	42	8	21
19	39	13	19±0,1	39	13	45	42	8	21
20	39	13	20±0,1	39	13	45	42	8	21
20	42	13	20±0,1	42	13	50	45	10	23
22	42	13	22±0,1	42	13	50	45	10	23
24	47	14	24±0,1	47	14	60	50	10	24
25	42	14	25±0,1	42	14	50	45	10	24
25	47	14	25±0,1	47	14	60	50	10	24
28	54	15	28±0,1	54	15	68	57	10	25
30	54	15	30±0,1	54	15	68	57	10	25
32	54	15	32±0,1	54	15	68	57	10	25
35	60	16	35±0,1	60	16	72	63	10	26
38	65	18	38±0,1	65	18	72	68	12	30
40	65	18	40±0,1	65	18	72	68	12	30
45	70	20	45±0,1	70	20	80	73	12	32
50	85	23	50±0,1	85	23	92	88	15	38
55	85	23	55±0,1	85	23	92	88	15	38
60	105	30	60±0,1	105	30	115	110	15	45
70	105	32	70±0,1	105	32	115	110	15	47

主动驱动型 FA positive driving

选型参数 Designation			D1	D3	D4	D7	L3	L4	D	A	B	
Type 1	8	18	11	8±0,1	18	24	22	11±0,5	4	14	2,5	6
	12	32	12,8	12±0,1	32	35	38	12,8+0,5	8	24	4	10
	14*	32	12,8	14±0,1	32	38	38	12,8+0,5	8	28	4	10
	15	32	12,8	15±0,1	32	38	38	12,8+0,5	8	28	4	10
	16*	32	12,8	16±0,1	32	38	38	12,8+0,7	8	28	4	10
	16*	39	12,8	16±0,1	39	42	42	12,8+0,7	8	32	4	10
	17	39	12,8	17±0,1	39	42	42	12,8+0,7	8	32	4	10
	18	39	12,8	18±0,1	39	42	42	12,8+0,7	8	32	4	10
	19*	39	12,8	19±0,1	39	42	42	12,8+0,7	8	32	4	12
	20	39	12,8	20±0,1	39	42	42	12,8+0,7	6	32	4	12
Type 2	24*	48	13,5	24±0,1	48	51	50	13,5+1	10	40	6	12
	25	48	13,5	25±0,1	48	51	50	13,5+1	10	40	6	12
	28	55	15	28±0,1	55	58	57	15+1	10	45	6	12
	30	55	15	30±0,1	55	58	57	15+1	10	45	6	12
	32	55	15	32±0,1	55	58	57	15+1	10	47	6	12
35	61	16	35±0,1	61	64	63	16+1	10	52	7	12	

* 根据订单生产 - Production on order